

Plate check valve

Reliable non-slam protection for pulsating gas flows

Production processes are network

Success requires that people and machines work together in unison.

Anyone who is integrated into the day-to-day production process interacts with technology, knows the pulse of the machines, their language, as well as their requirements and needs. Products made by HOERBIGER are more than state-of-the-art. As a HOERBIGER customer, you have the technological edge that allows you to always stay several steps ahead

of the market. Efficiency, precision and durability are a part of HOERBIGER products, just as reliability and flexibility are hallmarks of HOERBIGER services. HOERBIGER Experience is the ideal approach when it comes to a reliable, long-lasting partnership on an equal footing.

The advantages at a glance:

- Most robust check valve design in turbulent or pulsating flow conditions
- Minimal preventive maintenance required
- Excellent durability even in varying operating conditions
- Increased flexibility in piping isometry / simplification of engineering
- Designed and engineered to fit customer specific requirements
- Worldwide service centers close to customer

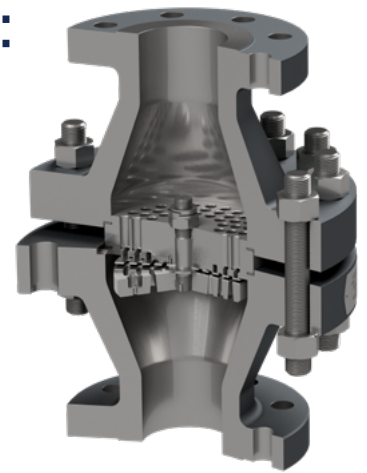

“Where rapidly fluctuating gas flow is encountered, compressor-type check valves such as the HOERBIGER plate check valve are a good choice.”

(Smith P. and Zappe R.W. 2004, Valve Selection Handbook)

Technical data

Process fluid	1200 rpm maximum gaseous, any composition
Flow condition	constant turbulent pulsating
Body configuration	wafer-type lug-type bell-type
Size	NPS 1/2" – NPS 16" DN10 – DN400
Pressure rating	Class 150 – Class 2500 PN10 – PN400
Codes & standards	ASME B16.34 API 594, API 6D PED 2014/68/EU
Flange dimensions & facings	ASME B16.5 DIN EN 1092-1 customer specification
Face-to-Face dimensions	ASME B16.10 API 594, API 6D EN customer specification
Material Selection:	In accordance to ASME API EN NACE and customer specification;
Certification:	CE acc. PED 2014/68/EU TRTS 010 & 032 (GOST)

Proven reliability over decades

Check valves are critical devices that not only prevent equipment from damaging, but also prevent safety risks caused by reverse flow. There are a wide variety of different check valve-types from numerous manufacturers available on the market. Engineers of our customers are generally challenged to select technological and economical suitable solutions for

their specific application. HOERBIGER plate check valves prove their advantages in challenging flow conditions like pulsating or turbulent flow since the 1950's. In other cases, fast response - that means short closure time - might be the technological advantage which is from priority for the specific application.

This is how the plate check valve works

- The high dynamic design of HOERBIGER plate type check valves is characterized by low moving masses, low valve lift and the spring loaded valve plate.
- HOERBIGER plate type check valves permit uncountable opening and closing cycles without negative impact on the service life due to their robust design.
- Due to their flexible design, HOERBIGER plate check valves can be exactly fitted to customer specific requirements.

Why choose the HOERBIGER plate check valve?

- The high dynamic valve characteristics of HOERBIGER plate check valves protect reliably from back-flow and thus, increase the availability of your high value equipment.
- HOERBIGER plate check valves are almost wear-free, leading to a reduced amount of maintenance.
- HOERBIGER plate check valves can be installed in any position and orientation. This either simplifies engineering or increases the flexibility of piping isometry.

Robust design

Metallic, friction free guided valve plate
optional damping plate

Most dynamic check valve design

Spring loaded valve plate
Low axial valve lift
Low moving mass

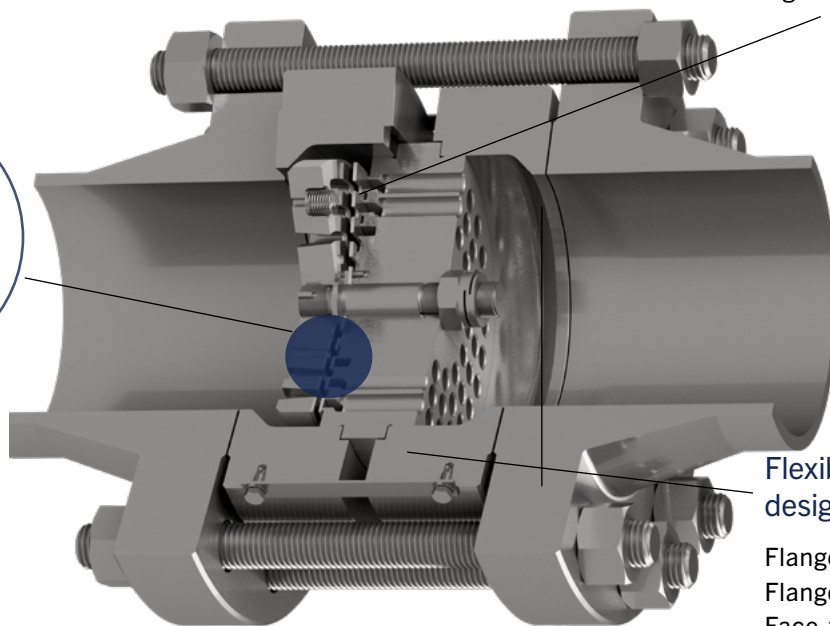
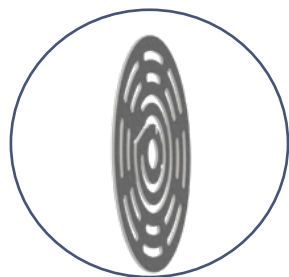

Flexible modular design

Flange dimensions
Flange facing
Face-to-Face dimensions
Material selection
Painting system



Learn more by visiting
www.hoerbiger.com/plate-check-valve
today!



Contact us for
more information!

Locally close to our customers – globally successful: HOERBIGER is active worldwide in 40 countries on all continents, with 6,477 employees at 130 locations – including 30 production plants – delivering reliable solutions for better performance, increased safety, and fewer emissions. In 2024, we generated sales of 1.466 billion Euros. For customers from the energy sector, the process industry, the automotive industry, the mechanical engineering industry, safety technology, and the electronics industry, HOERBIGER offers performance-defining products, and services that make the difference. With innovations for decarbonization and energy transition, HOERBIGER is already enabling change today for a better tomorrow. As majority shareholder, the HOERBIGER Foundation preserves the 130-year-old entrepreneurial heritage and guarantees stability, independence, and a future-oriented strategy.

HOERBIGER.COM

All rights reserved. Subject to change without notice © Copyright HOERBIGER 2025

